

International Nite Class Association

Class Rules

Revised: October 29, 2018

Revised: July 30, 2019

NOTES ON REVISIONS

- Revisions approved on 10/29/2018:
 - change all references of International Nite Ice Yacht Association (INIYA) to International Nite Class Association (INCA)
 - changed “ice boat” or “boat” to “ice yacht” or “yacht”.
- Revisions approved 7/30/2019:
 - Section G: Clarified runner dimensions, profile, crown, full-length stiffeners.
 - Section L: Changed minimum weight of skipper and led from 180 lbs. to 190 lbs.

- The following rules have been formulated by the Technical Committee with the intention to maintain the low cost, one design concept of the Nite Class Ice Yacht.
- Any innovation or variation not covered by these rules, which gives the skipper an advantage in speed, or handling over his competitors, or increases the cost unduly, will not be allowed unless the Committee feels that the rules should be changed to incorporate such an innovation.
- Drawings accompanying these rules are intended to assist in construction of a Nite Ice Yacht. Where written rules and drawings are ambiguous or in conflict, the technical committee shall be contacted for interpretation.

A. Fuselage

1. The fuselage will be one of polyester reinforced glass fibre laminations. The fuselage will be produced by class-approved builders only and is not subject to structural modification by the owner.
2. The minimum weight of the boat including rigging and parts necessary for sailing shall be 270 lbs.
3. Corrector weights, if used, shall be permanently installed to the front cockpit bulkhead.
4. Distance from bow runner king bolt to front edge of runner plank shall be 14' 1 1/2".
5. Distance from bow runner king bolt to mast step shall be 9' 1 1/2".
6. Distance from bow runner king bolt to runner bolt of side chock shall be 14' 5 1/2".

B. Steering

1. Steering shall be accomplished by means of a wheel of not less than 13" in diameter mounted horizontally below the deck and connected to the steering runner chock by cable. The minimum distance between the bottom of the wheel and the floor of the boat shall be 10".
2. Foot steering with no mechanical advantage can be added.

C. Runner Plank

1. The runner plank shall be constructed of wood with a minimum of two plies and a maximum of three plies; it must be solid.
2. Dimensions are as follows:

a. Length	11'2"	minus 1"	plus 0"
b. Width @ Centerline	8"	minus 1/4"	plus 1/4"
c. Width @ Ends	6 3/4"	minus 1/4"	plus 1/4"
d. Thickness @ Centerline	2 1/8"	minus 1/8"	plus 1/4"
e. Thickness @ Ends	1 3/4"	minus 1/4"	plus 1/4"
3. The unweighted plank is to have a positive crown with a maximum crown of 2 3/4".
4. Maximum runner cut shall be 11'; minimum runner cut shall be 10'10".
5. Fiberglass may be added.

D. Springboard

1. The springboard shall be constructed of wood with two equal plys; it must be solid.
2. Dimensions are as follows:
 - a. Length 72" minus ¼" plus 4"
 - b. Width 7 ¼" minus ¼" plus ¼"
 - c. Thickness 1 ½" minus 1/8" plus ¼"
3. Springboard is to have positive crown, with a maximum crown of 3"
4. Fiberglass may be added.

E. Mast

1. The mast shall be constructed of wood with a maximum of three laminations.
2. Dimensions are as follows:
 - a. Length 18' minus 2" plus 2"
 - b. Width @ Widest Point 5 ¾" minus ¼" plus ¼"
 - c. Thickness @ Center 2 3/8" minus 1/8" plus 1/8"
 - d. Thickness @ Top 2" minus ¼" plus ¼"
3. Leading edge profile to be a fair curved shape. Cut out section or radical shape variations for the purpose of compliance with measurement dimensions is not permitted.
4. Mast shall be hollow to permit internal halyard.
5. A full-length halyard shall be installed.
6. Fiberglass may be added **to repair a damaged section. Fiberglass may also be used to straighten a mast; the maximum allowable is one layer of 10 oz. Fiberglass on one side only. Technical committee ruling March 2001**
7. Metal or plastic sail tunnel may be added.
8. There shall be two 1-inch bands of contrasting color on the mast. The bottom edge of the upper band shall be 17' 9" from the bottom of the mast ball. The bottom edge of the lower band shall be 13" from the bottom of the mast ball. The sail must set between these bands. (7/30/2019)
9. Only the following fittings are permitted on the mast:
 - a. Sheave and cleat for sail halyard.
 - b. Hound assembly to hold rigging.
 - c. A sliding gooseneck track.
 - d. Mast step.
10. Masthead halyard catch shall not be allowed.

F. Boom

1. The boom shall be constructed of wood and shall be solid.
2. Dimensions are as follows:
 - a. Length 7'3 1/2" minus 1" plus 1"
 - b. Width 3 3/4" minus 1/4" plus 1/4"
 - c. Thickness 1 1/2" minus 1/8" plus 1/8"
3. Metal or plastic tunnel (sail) may be added.
4. Fiberglass may be added.
5. There shall be a band of contrasting color on the boom. The inner edge of sail band shall be not more than 7'4" from the edge of the mast or its continuations.
6. A sliding gooseneck fitting shall be used.

G. Runners

1. Material
 - a. Runners shall be constructed of steel plate of any grade including tooling steel up to D-2 grade.
 - b. Stainless steel may not be used. *Technical committee ruling 1999*. This includes magnetic and no- magnetic stainless.
2. Profile shape
 - a. The shape of the runner shall fit in the official class plans. See diagram #1
3. Dimensions
 - a. Length shall be 29.5" overall.
 - b. Height is measured on a complete runner. The maximum height is 5" overall. The minimum overall height allowed is 4.25".
 - c. Thickness can be measured anywhere on the blade of the runner. Minimum thickness is .250". The maximum thickness .250" plus .015".
4. Stiffeners
 - a. Shall be constructed of aluminum.
 - b. May be full length for all runners.
 - c. Shape is defined in diagram #2.
 - d. May be painted, anodized or coated.
5. Heat treating
 - a. Runners may be heat treated either by oven or torch.
 - b. Heat treating is not mandatory.
6. Surfacing
 - a. Runners may be surfaced to be brought into thickness tolerances.
 - b. Surfacing may be done by Blanchard ground or by a rotary method or style.
7. Coatings
 - a. Runners may be coated for maintenance purposes only.
 - b. Coatings allowed: Nickel Teflon, E-coat, paint, hard coat, Epoxy Teflon, or plating.
8. Crown
 - a. Crown may be up to 15" in length plus .5".
 - b. Crown shall be no greater than 1/32".
9. Cutting edge
 - a. The angle of the cutting edge is +/- 45 degrees

10. Shims

- a. Material may be affixed to the runner on the area contained by the chock solely for the purpose of creating better runner alignment.
- b. This material may be affixed in any manner. (2/6/2016)

11. Grandfather clause 5/1/19

Existing runners shall be Grandfathered into compliance provided a minimum height of 4.25" is met along with a thickness of .250". The existing coatings of the blade are permissible, however, they may not be recoated. Crown shall be no greater than stated in this section.

12. Construction of new runners

The official class CAD files shall be the only method used to manufacture new runners. The use of the files shall be made available by the BOD of the INCA upon review and payment of file royalty. Runners must be made from these licensed files only to be considered class-legal equipment.

H. Side Chocks

- 1. Side chocks are to be made of ¼" mild steel plate (1020), unheat-treated.
- 2. Chocks are to be of welded construction.
- 3. Chocks are to be single bolt, jaw type. Pillow block chocks are not allowed.
- 4. Liners or inserts in chocks are not allowed.
- 5. The 1" slot containing the runner is not to be machined.
- 6. Chocks are to be secured to the ends of the plank by bolts only. In addition to bolts, chocks may be glued to the plank.
- 7. Dimensions are as follows:
 - a. Length 7"
 - b. Width 3"
 - c. Jaw Opening 1"

I. Bow Chock

- 1. The bow chock is to be made of mild steel plate (1020) unheat-treated.
 - a. Width shall not exceed 10 ½"
 - b. Length 4"
 - c. Height 2 ¾"
 - d. Jaw opening 1"
- 2. Bow chocks with spring absorption device will not be permitted.

J. Rigging

1. The mast shall be supported by one forestay and one shroud to each side. These shall be of steel wire of a diameter not less than 1/8".
2. No additional rigging or fittings are permitted, the purpose of which is to affect the bend, rake or swivel of the mast.
3. Each shroud shall be attached to the hull and plank tangs by means of plates or tubes having a row of adjustment holes. **A Staymaster fitting may be installed on the forestay in lieu of a plate or tang. January 2006**
4. Sail trim shall be accomplished by means of line and pulleys. Wire or any mechanical means shall not be permitted. Pulleys to be attached to hull on the centerline.
5. Cushions of a size such as to restrict the size of the cockpit shall not be permitted.
6. Position of tangs on spar shall be per measurement diagram.
7. Hounds tang shall be bolted to the mast. The shrouds and forestay shall be connected to the hounds tang by means of a link chain **or a single piece steel tang, it must be the same length as the chain. Approved Dec. 1992 after one-year trial period**

K. Sail

1. The sail shall measure 15'6" on the leach, tolerance -2" from the center of the forward most headboard hole to the center of the after most clew ring. The clew and tack ring shall not be more than 1" from an edge of the sail. The forward most headboard hole shall be no more than 1" from an edge of the sail and 1 1/2" from the front. See mast and boom bands for the luff and foot measurement of the sail Maximum cringle hole size 3/4".
2. The maximum roach, measured at right angles to the straight line between the center of the clew ring and the center of the forward most headboard hole, shall be 10".
3. There shall be 5 full length batten pockets which shall be 90 degrees +/- 2 degrees of a straight line between the center of the clew ring and the center of the forward most headboard hole. Pockets shall be spaced on 32" centers from the top of the sail.
4. The top girth points shall be found by measuring four feet from the center of the forward most headboard hole along the luff and the leach, respectively. The bottom girth points shall be found by measuring eleven feet six down from the center of the front hole in the headboard down the leach and twelve feet two inches down the luff from the front headboard hole. The maximum girths including both ropes shall be: Upper 2'10" and Lower 6'4".
5. Maximum headboard extension from bolt rope is 4 1/2"
6. All sail measurements shall be taken with just enough tension to remove wrinkles.
7. Cringles shall not be permitted in the luff for making adjustments to luff tension.
8. Battens
 - a. There shall be 5 full-length battens.
 - b. Maximum width of battens shall be 2".
 - c. Allowable construction materials are wood, fiberglass and fiberglass with foam core.

L. Other Rules

1. At a sanctioned regatta, only one of the following items shall be allowed: hull, runner plank, springboard and mast. Two of the following items shall be allowed: sails, booms, sets of runners. Batten sets are unlimited.
2. Crash helmets are required for all fleet races or regattas.
3. Creepers are allowed.
4. Minimum weight of skipper and lead shall be 190 lbs. Above 190 lbs., lead may be added or removed before and after each race.
5. If a hull, runner plank, springboard, mast or other limited use item is broken during a sanctioned regatta; the race committee shall be notified and will make a decision as to the use of a replacement part.
6. Use of carbon fiber, Kevlar or other exotic or costly material in any phase of the boat or parts construction is prohibited.

Diagram # 1

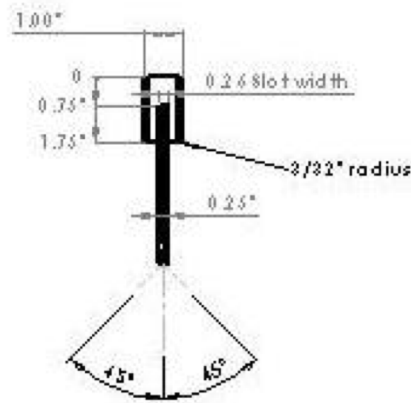
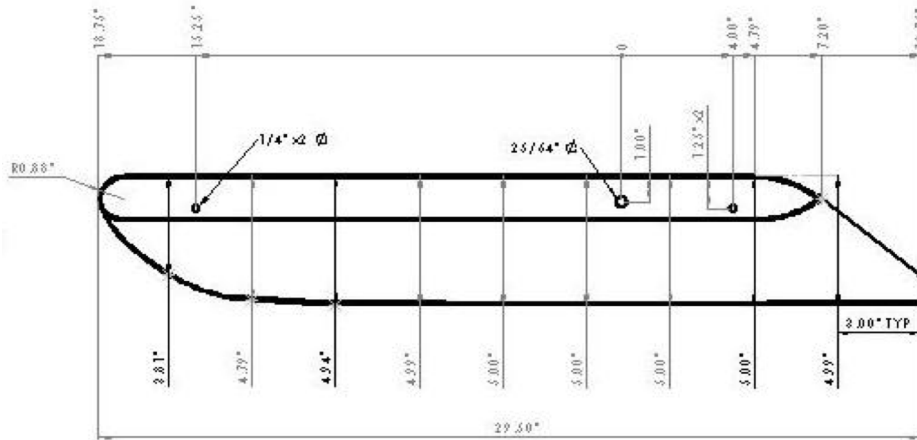

Diagram # 2