

Effective date: 11 May 2020

Status: Approved



Class Rules

International OK Dinghy Class Association



The OK Dinghy was designed in 1957 by Knud Olsen and was adopted as an International Class in 1972.

sport / nature / technology



INDEX

PART I – ADMINISTRATION

Section A – General

A.1	Language	4
A.2	Abbreviations	4
A.3	Authorities	4
A.4	Administration of the Class ..	4
A.5	World Sailing Rules	4
A.6	Class Rules Variations	4
A.7	Class Rules Amendments ...	5
A.8	Class Rules Interpretation ...	5
A.9	International Class Fee and World Sailing Building Plaque	5
A.10	Sail Numbers	5
A.11	Hull Certification	5
A.12	Initial Hull Certification	6
A.13	Validity of Certificate	6
A.14	Hull Re-Certification	6
A.15	Retention of Certification Documentation	6

Section B – Boat Eligibility

B.1	Class Rules and Certification	7
B.2	Event Inspection	7
B.3	Event Limitation Marks	7

PART II – REQUIREMENTS AND LIMITATIONS

Section C – Conditions for Racing

C.1	General	8
C.2	Crew	8
C.3	Personal Equipment	8
C.4	Advertising	8
C.5	Portable Equipment	9
C.6	Hull	9

C.7	Hull Appendages.....	10
C.8	Rig	11
C.9	Sails	12

Section D– Hull

D.1	Parts.....	14
D.2	General	14
D.3	Hull Shell	15
D.4	Deck	15
D.5	Buoyancy Tanks & Bulkheads	15
D.6	Gunwale and Rubbing Strakes	16
D.7	Assembled Hull	16

Section E – Hull Appendages

E.1	General	20
E.2	Centreboard	20
E.3	Rudder, Rudder Blade, Rudder Stock and Tiller	21

Section F – Rig

F.1	General	22
F.2	Mast	22
F.3	Boom	24
F.4	Running Rigging	25

Section G – Sails

G.1	General	25
G.2	Sail	25

PART III – APPENDICES

H.1	Measurement Diagrams	29
H.2	Official Plans	36
H.3	Definitions	36

INTRODUCTION

*The intention of the OK Dinghy **class rules** is to ensure that the boats are as alike as possible in all respects affecting performance. However, within these rules, variations in the construction of the boats are permitted.*

International OK Dinghy hulls, hull appendages, rigs and sails are measurement controlled.

OK Dinghy sails may be measured under World Sailing's In House Certification (IHC) programme.

OK Dinghy hulls, hull appendages, booms and sails may be built by any manufacturer.

*OK Dinghy masts shall only be manufactured by a licensed builder except when constructed from wood or aluminium alloy when there is no restriction. These **class rules** apply to both licenced and un-licenced mast builders.*

*OK Dinghy hulls, hull appendages, rigs and sails may, after having left the manufacturer, only be altered to the extent permitted in Section C of the **class rules**.*

Owners and crews should be aware that compliance with rules in Section C may NOT be checked as part of the certification process.

*Rules regulating the use of equipment during a race are contained in Section C of these **class rules**, in ERS Part I and in the Racing Rules of Sailing.*

*This introduction only provides an informal background and the International OK Dinghy **class rules** proper begin on the next page.*

PLEASE REMEMBER

**THESE RULES ARE CLOSED CLASS RULES WHERE IF
IT DOES NOT SPECIFICALLY SAY THAT YOU MAY –
THEN YOU SHALL NOT.**

**COMPONENTS, AND THEIR USE, ARE DEFINED BY
THEIR DESCRIPTION.**

PART I – ADMINISTRATION

Section A – General

A.1 LANGUAGE

- A.1.1 The official language of the class is English and in case of dispute over any translation, the English text shall prevail.
- A.1.2 The word “shall” is mandatory and the word “may” is permissive.

A.2 ABBREVIATIONS

- A.2.1 MNA World Sailing Member National Authority
- OKDIA International OK Dinghy Class Association
- NCA National Class Association
- ERS Equipment Rules of Sailing
- RRS Racing Rules of Sailing
- IHC In House Certification (World Sailing)

A.3 AUTHORITIES

- A.3.1 The international authority of the class is World Sailing, which shall co-operate with the OKDIA in all matters concerning these **class rules**.
- A.3.2 Neither World Sailing, an MNA, the OKDIA, an NCA, a **certification authority** or an **official measurer** are under any legal responsibility in respect of these **class rules** and the accuracy of measurement, nor can any claim arising from these be entertained.
- A.3.3 Notwithstanding anything contained herein, the **certification authority** has the authority to withdraw a **certificate** and shall do so on the request of World Sailing.

A.4 ADMINISTRATION OF THE CLASS

- A.4.1 The administering authority is the OKDIA. Except as provided for under A.4.2, the **certification authority** shall be the MNA. The MNA may delegate part or all of its functions, as stated in these **class rules**, to a NCA.
- A.4.2 In countries where there is no MNA, or the MNA does not wish to administrate the class, its administrative functions as stated in these **class rules** shall be carried out by the OKDIA which may delegate the administration to an NCA.

A.5 WORLD SAILING RULES

- A.5.1 These **class rules** shall be read in conjunction with the ERS.
- A.5.2 Except where used in headings, when a term is printed in “**bold**” the definition in the ERS applies and when a term is printed in “*italics*” the definition in the RRS applies.
- A.5.3. The class plans, measurement form and measurement diagram are complementary to these **class rules**.

A.6 CLASS RULES VARIATIONS

- A.6.1 At World, Continental or Regional Championships the Notice of Race and/or Sailing Instructions may change the **class rules** only with the agreement of the OKDIA and World Sailing.

A.6.2 At National events the Notice of Race and Sailing Instructions may change the **class rules** only with the agreement of the NCA and the MNA.

A.6.3 At any other class events, these **class rules** shall not be changed by the Notice of Race and Sailing Instructions.

A.7 CLASS RULE AMENDMENTS

A.7.1 Amendments to these **class rules** are subject to the approval of World Sailing in accordance with World Sailing Regulations.

A.8 CLASS RULES INTERPRETATIONS

A.8.1 Interpretation of **class rules** or discrepancy between the **class rules**, measurement form and measurement diagram shall be made in accordance with World Sailing Regulations.

A.9 WORLD SAILING BUILDING PLAQUE

A.9.1 The builder shall pay the Building Plaque Fee on each **boat** built, whether or not it is subsequently measured and registered. World Sailing Building Plaques may be purchased by the builder from the NCA or from OKDIA when the NCA does not want to administer or where there is no NCA. A receipt shall be issued bearing the same number as the Plaque.

A.10 SAIL NUMBERS

A.10.1 Sail numbers shall be issued by the **certification authority** on receipt of evidence that the Building Plaque Fee has been paid.

A.10.2 Sail numbers shall be issued in consecutive order starting at "1".

A.10.3 In countries where consecutive numbering has not been applied, they shall start from a number approved by the OKDIA.

A.10.4 Personal Sail Numbers (PSN) may be issued by the NCA of the sailors' MNA. Personal Sail Numbers are additional to the sail numbers issued to all **boats**. If the use of a Personal Sail Number is likely to cause confusion, a Race Committee may require that a **boat** use the sail number issued to that **boat** or another agreed number. The NCA shall issue official OKDIA PSN certificates.

A.11 HULL CERTIFICATION

A.11.1 No **boat** shall take part in *racing* unless it has a valid measurement **certificate** in the owner's name. The measurement **certificate** is only valid if the owner is a current member of a NCA or, if there is no NCA in their nation, a member of the OKDIA.

A.11.2 A **certificate** shall record the following information:

(a) Class.

(b) **Certification authority.**

(c) Sail number issued by the **certification authority.**

(d) World Sailing Building Plaque number.

(e) Owner.

(f) Craft identification number (CIN) where appropriate.

(g) Builder/Manufacturers details.

(h) Date of issue of initial **certificate.**

(i) Name of the original measurer.

(j) Date of issue of current **certificate.**

- (k) Total weight of the **hull** as measured in C.6.1.
- (l) Total weight of **corrector weights**.
- (m) Number and position of **correctors weights** and their weight as per C.6.2.
- (n) Signature of owner.

A.12 INITIAL HULL CERTIFICATION

- A.12.1 For a **certificate** to be issued to a **hull** not previously **certified**:
- (a) **Certification control** shall be carried out by the **official measurer** who shall complete the appropriate documentation.
 - (b) The documentation and **certification** fee, if required, shall be sent to the **certification authority**.
 - (c) Upon receipt of a satisfactorily completed documentation and **certification** fee, if required, the **certification authority** may issue a **certificate**.

A.13 VALIDITY OF CERTIFICATE

- A.13.1 A **hull certificate** becomes invalid upon:
- (a) the change to any items recorded on the **hull certificate** as required under A.11.2.
 - (b) withdrawal by the **certification authority**,
 - (c) the issue of a new **certificate**.

A.14 HULL RE-CERTIFICATION

- A.14.1 The **certification authority** may issue a **certificate** to a previously certified **hull**:
- (a) when it is invalidated under A.13.1(a) or (b), after receipt of the old **certificate**, and **certification** fee if required.
 - (b) when it is invalidated under A.13.1 (c), at its discretion.
 - (c) in other cases, by application of the procedure in A.12.

A.15 RETENTION OF CERTIFICATION DOCUMENTATION

- A.15.1 The **certification authority** shall:
- (a) retain the original documentation upon which the current **certificate** is based.
 - (b) upon request, transfer this documentation to the new **certification authority** if the **hull** is exported.
- A.15.2 The NCA shall send the OKDIA details of **certificates** issued with the names and addresses of the owners.

Section B – Boat Eligibility

For a **boat** to be eligible for *racing*, it shall comply with the rules in this section.

B.1 CLASS RULES AND CERTIFICATION

B.1.1 The **boat** shall:

- (a) be in compliance with the **class rules**.
- (b) have a valid hull **certificate**.
- (c) have valid **certification marks** where applicable.

B.2 EVENT INSPECTION

B.2.1 The **equipment inspectors** for an event should be appointed by the Organising Authority or by the Race Committee when delegated to them, except that for World and Continental Championships they shall first be approved by the OKDIA. The role of **equipment inspectors** at an event is to verify that equipment has not been subsequently altered since it was originally measured (other than as is permitted within these rules) using whatever inspection methods they deem appropriate. Should this comparison reveal deviation greater than what the **equipment inspector** considers to be within the rules, the matter shall be reported to the Race Committee and Jury.

B.3 EVENT LIMITATION MARKS

B.3.1 Where an event uses **event limitation marks** these marks shall not be removed during the event. If an **event limitation mark** becomes damaged or lost this shall be reported to the Race Committee or Event Technical Committee as soon as practical.

PART II – REQUIREMENTS AND LIMITATIONS

The **crew** and the **boat** shall comply with the rules in Part II when *racing*. In case of conflict Section C shall prevail.

The rules in Part II are **closed class rules**. **Certification control** and **equipment inspection** shall be carried out in accordance with the ERS except where varied in this Part.

Section C – Conditions for Racing

C.1 GENERAL

C.1.1 RULES

- (a) RRS 42.3(c) is changed to add: "When the **sail** is pumped it shall be done with the mainsheet turning through at least three blocks between the **boom** and the **crew**. The final block shall be securely fastened in the cockpit area."

C.2 CREW

C.2.1 LIMITATIONS

- (a) The **crew** shall consist of 1 person.
- (b) No **crew** is permitted to take part in *racing* unless he/she is a member of his/her NCA. If there is no NCA, then the **crew** must be a member of a NCA approved by the OKDIA. Any **crew** that takes part in *racing* in contravention of this rule may be disqualified without a hearing.

C.3 PERSONAL EQUIPMENT

C.3.1 MANDATORY

The **crew** shall wear a **personal flotation device** to the minimum standard ISO 12402:5 (CE 50 Newtons), or EN393, or USCG Type III, or AUS PFD II, or equivalent, and suitable for their size and weight, except for short periods when changing or adjusting clothing.

C.3.2 TOTAL WEIGHT

The total weight of worn clothing and equipment shall not exceed 10 kg, weighed as per RRS Appendix H.

C.4 ADVERTISING

C.4.1 LIMITATIONS

Advertising may be displayed only in accordance with World Sailing Regulation 20 - Advertising Code.

C.5 PORTABLE EQUIPMENT

C.5.1 FOR USE

(a) MANDATORY

(1) GPS tracking devices and cameras, if required by the Sailing Instructions.

(b) OPTIONAL

(1) Any electronic or mechanical timing devices.

(2) Not more than two compasses are permitted on board. If electronic, the compass shall only display heading, tacking angle, timing and internal information relating to the compass.

(3) Any mechanical wind indicators.

(4) Any hand bailers and/or buckets.

(5) Any anchor which may be compulsory if stated in the Notice of Race AND Sailing Instructions

(6) Any consumables.

(7) Any writing equipment.

(8) Any spares such as ropes, fittings and tools.

C.5.2 NOT FOR USE

(a) MANDATORY

(1) Any floating towing rope with a minimum length of 10 m of not less than 6 mm in diameter, and which shall be accessible without opening a watertight bulkhead.

(b) OPTIONAL

(1) One paddle.

(2) Mooring line.

(3) Flags.

(4) Bags.

(5) Anchor warps.

(6) Fenders.

C.6 HULL

C.6.1 WEIGHT

	min	max
The hull weight in dry condition including fixed compass(s), pulley blocks attached to the hull and all control lines but excluding the mainsheet.	72 kg	

C.6.2 CORRECTOR WEIGHTS

(a) **Corrector weights** of not more than 10 kg are allowed.

(b) If the weight of the **hull** is under the minimum limit, **corrector weights** of not more than 5 Kg and of approximately equal weight and made of any material shall be fastened so as to touch the aft face of the bulkhead at station 2 and situated within an area of 150 mm athwartships, 150 mm vertical and 80 mm aft from the intersection point of the **sheerline** and station 2 bulkhead.

- (c) Additional **corrector weights** of not more than 5 kg and of approximately equal weight and made of any material may be used and shall only be attached to the underside of the deck at bow and transom

C.6.3 MODIFICATIONS, MAINTENANCE AND REPAIR

The following is permitted without re-**certification** or approval of the **certification authority**. Unless stated otherwise items mentioned in this section may be obtained from any manufacturer or supplier.

MODIFICATIONS

- (a) Holes may be made in the **hull** for the fixing of fittings.
- (b) Any line bags, and additional fairleads, cleats, jammers and pad eyes, may be placed in the **hull**.

MAINTENANCE

- (c) Routine maintenance such as small repairs, painting, sanding and polishing is permitted without re-measurement and re-**certification**.

REPAIR

- (d) The **hull** may be altered or repaired provided that it continues to comply with the **class rules**.

C.6.4 LIMITATIONS

- (a) Only one **hull** shall be used during an event, except when lost or unintentionally damaged beyond repair. Such replacements shall be made only with the approval of the Event Technical Committee.
- (b) Inspection hole covers and drainage plugs shall be kept in place and closed, except for short periods of time when items are placed or removed.
- (c) The distance from the masthead halyard sheave to the top of the transom at the centreline shall not change by more than 100 mm between the **mast** being in its most aft position to its most forward position, with the **mast** facing fore/aft.
- (d) The distance from the masthead halyard sheave to the top of the transom at the centreline shall not change by more than 150 mm between the **mast** being in its most aft position when facing fore/aft and the **mast** being in its most forward position when the **mast** is rotated through 90 degrees to the centreline.

C.7 HULL APPENDAGES

C.7.1 MODIFICATIONS, MAINTENANCE AND REPAIR

The following is permitted without re-**certification** or approval of the **certification authority**. Unless stated otherwise items mentioned in this section may be obtained from any manufacturer or supplier.

MODIFICATIONS

- (a) The fixings and fastenings of the **hull appendages** may be replaced by any fixing and fastening.

MAINTENANCE

- (b) Routine maintenance such as small repairs, painting, sanding and polishing, is permitted without re-measurement and re-**certification**.

REPAIR

- (c) **Rudders** and **centreboards** may be altered or repaired providing that they continue to comply with the current **class rules**.

C.7.2 LIMITATIONS

- (a) Any number of **hull appendages** may be used during an event. If required by the Notice of Race or Sailing Instructions, not more than one **centreboard** and one **rudder** may be used during an event, except when a **hull appendage** has been lost or unintentionally damaged beyond repair. Such replacements shall be made only with the approval of the Event Technical Committee.
- (b) When a metal **centreboard** (aluminium or otherwise) needs to be replaced, it may only be replaced by an aluminium **centreboard** of maximum thickness of 6 mm and otherwise shall be compliant with section E.2. No other metals are permitted.
- (c) Any tiller may be used.

C.7.3 CENTREBOARD

(a) DIMENSIONS

	min	max
Extension below keel , excluding keel bands		800 mm

(b) LIMITATIONS

- (1) When fully raised the **centreboard** shall not project below the keel bands.

C.7.4 RUDDER

(a) DIMENSIONS

	min	max
The distance from the top leading edge of the rudder , extended in a straight line as necessary, to (i) transom at deck level (ii) transom at hull datum point		45 mm 45 mm
Difference between (i) & (ii)		5 mm
Vertical distance of the intersection of the leading edges of the rudder to the hull datum point .		50 mm

(b) LIMITATIONS

- (1) Unless changed by the Notice or Race or Sailing Instructions, lifting **rudder** blades shall be pinned or bolted in the down position in a separate place from the point at which the **rudder** blade pivots.
- (2) Any safety device shall be fitted to prevent the **rudder** becoming detached unintentionally.

C.8 RIG

C.8.1 MODIFICATIONS, MAINTENANCE AND REPAIR

The following is permitted without re-**certification** or approval of the **certification authority**. Unless stated otherwise, items mentioned in the section may be obtained from any manufacturer or supplier.

MODIFICATIONS

- (a) A device shall be fitted to the **boom** to prevent any part of the **sail** extending aft of the forward edge of the **outer limit mark**.

(b) Fittings and **spars** may be modified to accommodate different diameter bolts or rivets.

MAINTENANCE

(b) The **spars** may be re- anodised, polished or painted.

REPAIR

(c) **Masts** and **booms** may be altered or repaired providing that they continue to comply with the current **class rules**, except that alterations or repairs of more than one meter in length to **masts** made from materials other than wood or aluminium alloy, shall only be made by Licensed Mast Builders.

C.8.2 LIMITATIONS

(a) Any number of **masts** and **booms** may be used during an event. If required by the Notice of Race or Sailing Instructions, not more than one **boom** and one **mast** may be used during an event, except when an item has been lost or unintentionally damaged beyond repair. Such replacements shall be made only with the approval of the Event Technical Committee.

(b) Any **running rigging** may be used.

(c) The intersection of the aft edge of the **mast spar** and the top of the **boom spar**, each extended as necessary, shall not be below the upper edge of the mast **lower limit mark** when the boom spar is at 90 degrees to the mast **spar**.

(d) The **boom** shall be attached to the **mast** in such a way that the **boom** and the **mast** rotate as one.

(e) There shall be a security device to prevent the **mast** coming out of the **mast** step unintentionally.

(f) The **mast** position shall not be manually adjusted while *racing*.

C.8.3 MAST

(a) DIMENSIONS

	Min	Max
Lower point height	265 mm	275 mm

C.9 SAILS

C.9.1 IDENTIFICATION

National letters and **sail** numbers and **sail** insignia shall conform to RRS Appendix G.

C.9.2 MODIFICATIONS, MAINTENANCE AND REPAIR

The following is permitted without re-certification or approval of the **certification authority**. Unless stated otherwise items mentioned in this section may be obtained from any manufacturer or supplier.

MODIFICATION

(a) Addition of tell tales.

(b) Addition of camber stripes.

MAINTENANCE

(c) **Sails** may be cleaned.

REPAIR

- (d) **Sails** may be altered or repaired providing that they continue to comply with the **class rules**.

C.9.3 LIMITATIONS

- (a) Not more than 1 **sail** shall be carried aboard.
- (b) Any number of **sails** may be used during an event. If required by the Notice of Race or Sailing Instructions, not more than two **sails** may be used during an event, except when a **sail** has been lost or unintentionally damaged beyond repair. Such replacements shall be made only with the approval of the Event Technical Committee.
- (c) Battens may be placed in the **batten pockets**

C.9.4 USE

- (a) The **sail** shall be hoisted on a halyard. The arrangement shall permit hoisting and lowering of the **sail** at sea.
- (b) The highest visible point of the **sail**, projected at 90 degrees to the mast **spar**, shall not be set above the lower edge of the mast **upper limit mark**.
- (c) The intersection of the **leech** and the top of the boom **spar**, each extended as necessary, shall not be behind the fore side of the boom **outer limit mark**.
- (d) **Luff** and **foot** bolt ropes shall be in the **spar** grooves or tracks.

Section D – Hull

D.1 PARTS

D.1.1 MANDATORY

- (a) **Hull** shell.
- (b) Deck.
- (c) Buoyancy Tanks.
- (d) Bulkheads.
- (e) Gunwale Rubbing Strakes.

D.1.2 OPTIONAL

- (a) Floorboards.
- (b) Cockpit liner.

D.2 GENERAL

D.2.1 RULES

- (a) The **hull** shall comply with the **class rules** in force at the time of initial **certification**.
- (b) Alterations or replacements shall comply with current **class rules**.

D.2.2 MODIFICATIONS, MAINTENANCE AND REPAIR

- (a) **Hull** repairs shall be carried out so that the **boat** continues to comply with the **class rules**. Only materials listed in D.3.1 may be used for repairs.

D.2.3 DEFINITIONS

(a) HULL DATUM POINT

The **hull datum point** is the intersection of the transom and the bottom **hull** panels at the lowest point of the transom, extended if necessary and excluding the keel band.

- (b) At the measurement stations, the centre plane measurement points of the **hull** are at the intersection of the bottom panels, extended if necessary and excluding the keel band.
- (c) At the measurement stations, the chine points of the **hull** are at the intersection of the topside and bottom panels, extended if necessary.
- (d) At the measurement stations, a sheerline gauge as shown in diagram H.1.10, shall be used to find the **sheerline**
- (e) A cockpit liner is a moulded cockpit incorporating the bulkheads at stations 1 and 2. It may include a **centreboard** case cover, topside panels, flanges to connect with the **hull** shell and a moulding to hold the main-sheet block. All parts shall be made from GRP and/or GRP sandwich only.

D.2.4 IDENTIFICATION

- (a) The World Sailing Building Plaque shall be permanently placed by the builder on the starboard side of the aft cockpit bulkhead.
- (b) The **hull** shall carry the sail numbers and national letters, in figures not less than 20 mm high, either cut out, burned or engraved into either
 - (1) the hog
 - (2) the **centreboard** case in the cockpit
 - (3) on the bulkhead at station 2 on the centreline
 - (4) a plaque of any permitted material permanently attached to the

bulkhead at station 2 on the centreline.

D.2.5 MANUFACTURERS

- (a) The **hull** may be built by any amateur or professional builder.

D.3 HULL SHELL

D.3.1 MATERIALS

- (a) The **hull** shell, including the **centreboard** case, shall be built from one or a combination of:

- (1) Wood (solid or laminated)
- (2) GRP sandwich or wood sandwich
- (3) GRP

- (b) The **hull** may be covered with resin, gelcoat, paint, varnish or vinyl.

D.3.2 CONSTRUCTION

- (a) **Hull** shell and centreboard case thickness is optional, except that for foam sandwich construction it shall not exceed 25 mm including stringers.

- (b) Thickness of the **hull** shell, including any cockpit liner, with the exception of stringers, framing, deck and transom, shall be within 10 % along the length of the boat. No attempt shall be made to concentrate weight at any point. If it is suspected that this rule is being broken, an **equipment inspector** or an **official measurer** may authorise test holes to be drilled in the skin or structure. (For the purpose of this rule the thickness shall not include either paint, non-skid paint in the cockpit, fairing filler or repairs, reinforcements for the mast step, drain tube, bracket for mainsheet block or pads to secure flotation, or joins in the core).

- (c) Single skin wood boats may have an extra layer of plywood, with a maximum thickness of 4 mm, added on the cockpit floor from a maximum of 50 mm aft of station 1 to a maximum of 50 mm forward of station 2.

- (d) The surface of the **hull** may be checked with a flexible batten to ensure the curvature of the **hull** is fair.

- (e) When measured athwartships at the stations, the surface of the **hull** and topsides shall not be concave.

D.4 DECK

D.4.1 MATERIALS

- (a) The deck shall be built from one or a combination of:

- (1) Wood (solid or laminated).
- (2) GRP sandwich or wood sandwich.
- (3) GRP.

- (b) The deck may be covered with resin, gelcoat, paint, varnish or vinyl.

D.4.2 CONSTRUCTION

- (a) Deck thickness shall not exceed 25 mm.

- (b) The **sheerline** between stations 1 & 2 shall not be convex.

- (c) Measured athwartships the fore and aft decks shall not be concave.

- (d) A breakwater may be fitted between the **mast** and the mainsheet horse or track.

- (e) Struts to support the side-decks are permitted. The sum total side cross sectional area of the struts shall not exceed 50 cm².
- (f) Cockpit liners are allowed. The cockpit including bulkheads and any **centreboard** case cover and mouldings for attaching fittings may be made in one piece and attached into the **hull shell** providing that the finished **hull** complies with the measurements and rules in D.3, D.5 and D.7.2. Notwithstanding D.3.2.b, the joined topside panels may have an extra 2 mm of thickness to allow for glue. **Centreboard** case covers are permitted and shall not be wider than 90 mm at any point. Any connecting flange from the liner to the floor shall not be wider than 70 mm. For the purpose of this rule the flange may extend around any fittings on the floor such as bailers and mainsheet fixing brackets, providing they are all part of the same moulding. Any void between the **centreboard** case cover and case sides must be able to be inspected.

D.5 BUOYANCY TANKS AND BULKHEADS

D.5.1 MATERIALS

- (a) The buoyancy tanks and bulkheads shall be built from one or a combination of:
 - (1) Wood (solid or laminated)
 - (2) GRP sandwich or wood sandwich
 - (3) GRP
- (b) The bulkheads may be covered with resin, gelcoat, paint, varnish or vinyl.

D.5.2 CONSTRUCTION

- (a) Bulkhead thickness shall not exceed 12 mm for wood or GRP sandwich with a wood or cormat core, or 20 mm for GRP sandwich with a foam or end grain balsa core.
- (b) Two buoyancy tanks shall be formed by three watertight bulkheads. All the space aft of the cockpit shall form a buoyancy tank. All the space between the bulkhead at station 2 and the bulkhead forward of station 3 shall form a buoyancy tank.
- (c) Each tank shall have at least one and not more than three inspection holes if their covers are unthreaded and an unlimited number if the covers are threaded.
- (d) Each inspection hole shall have a watertight detachable cover capable of resisting accidental dislodgement.
- (e) Each tank may have a maximum of two drain holes into the cockpit.
- (f) Control lines passing through buoyancy tanks shall be inside watertight tubes.
- (g) The **mast** compartment (the area forward of the front bulkhead) shall drain into the cockpit through a tube.
- (h) A minimum of 0.12 m³ of closed cell expanded plastic foam material shall be securely fixed in the buoyancy tank forward of the cockpit.
- (i) Any buoyancy material may be added under the side decks to a point not lower than 80 mm below the **sheerline**. This buoyancy shall not be included in the requirements of D.5.2 (h).
- (j) The corners between the deck and bulkheads at stations 1 and 2 may be bevelled or shaped. Measured from the **hull datum point**, no part of the

bevel or shape forward of 1809 mm or aft of 785 mm shall be below the **sheer**.

D.6 GUNWALE AND RUBBING STRAKES

D.6.1 MATERIALS

The gunwale and rubbing strakes shall be built from one or a combination of:

- (a) Wood (solid or laminated).
- (b) GRP.

D.6.2 CONSTRUCTION

- (a) Gunwales shall run the full length of the **boat**.

D.6.3 LIMITATIONS

- (a) Gunwales shall not be positioned above the adjacent **sheerline**.

D.7 ASSEMBLED HULL

D.7.1 FITTINGS

(a) MANDATORY

- (1) Any towing eye on the foredeck near the stem head.
- (2) Any **mast** step.
- (3) Keel bands shall be fixed to the keel line of the **hull**. They shall run both sides of the centreboard case slot and may be faired together at either end. They may be part of the **hull** mould if built from GRP. They shall be built from one or a combination of:

- i. Wood (solid or laminated).
- ii. GRP.
- iii. Metal.
- iv. Plastic.

(b) OPTIONAL

- (1) Any fittings.
- (2) Any **mast** bearings for **mast** step and deck that may be adjustable.
- (3) Any floorboards.
- (4) Any self-bailers.
- (5) Any sheeting and centreboard hoists.
- (6) Any mainsheet track with one traveller or horse.
- (7) Any bracket or block to fasten a mainsheet block on floor or case.
- (8) Any foam floor mats for non-skid with max thickness of 6mm.
- (9) Any hiking pads, fitted to the side-decks and gunwales, provided they fall within the side deck measurements in D.7.2. However, padding up to 10 mm thick is allowed to cover the **sheerline** measured 90 degrees to the surface and shall not be more than 10 mm above the **sheerline** on the gunwale.

(c) LIMITATIONS

- (1) Toe straps shall not extend outboard.
- (2) The mainsheet track may extend outboard to the topside panel. If the side deck profile is cut away for this purpose, the panel on which the track sits shall satisfy the side-deck dimension rules.

- (3) Fittings made from exotic materials and/or CRP shall only be attached and shall not be integral to the **hull**, deck or cockpit including the internal structure. Any wear patches, protective pads and backing pads made from exotic materials and/or CRP shall not be recessed into these areas. For the purpose of this rule, exotic is defined in H.3.
- (4) The use of exotic materials (excluding EVA foam) and/or CRP is limited to wear patches, protective and backing plates, compass brackets, cleats, fairleads, pad eyes, blocks, traveller supports, gudgeons, pintles, hiking pads, **mast** bearings and chocks, **mast** bearing adjusting mechanisms and block organiser wings when they do not incorporate a **mast** bearing.
- (5) Hiking pads made from CRP, GRP, timber and exotics shall not exceed 550 mm in length and are limited to one per side.
- (6) The size and weight of all fittings, backing plates and their fastenings shall be fit for purpose and shall not be used to alter the weight distribution of the **hull**.

D.7.2 DIMENSIONS

The keel line shall be taken as the intersection line from the transom to the stem of the **hull** shell and the **hull** centre plane.

The sections shall be taken as vertical, transverse planes at the following positions:

	From hull datum point
Station 0	0 mm
Station 1	800 mm
Station 2	1800 mm
Station 3	2800 mm

The baseline shall be on the centre plane of the **hull** at the following vertical distances below the bottom of the **hull** as defined in D.2.3 (b):

At the hull datum point	200 mm from the hull shell
At station 3	28 mm from the hull shell

	Min	Max
Hull length excluding deck overlap but including any stem band	3990 mm	4010 mm
Vertical distance from baseline to bottom of hull shell		
At station 1	85 mm	105 mm
At station 2	0 mm	16 mm
At 3500 mm forward of hull datum point	90mm	110 mm
Horizontal distance along baseline from hull datum point to top of transom	0 mm	12 mm
Baseline to chine at Station 0	237 mm	257 mm

Baseline to sheerline at Station 0	433 mm	453 mm
Baseline to chine at Station 1	178 mm	198 mm
Baseline to sheerline at Station 1	449 mm	469 mm
Baseline to chine at Station 2	164 mm	184 mm
Baseline to sheerline at Station 2	482 mm	502 mm
Baseline to chine at Station 3	216 mm	236 mm
Baseline to sheerline at Station 3	537 mm	557 mm
Baseline to sheerline at stem	588 mm	608 mm
Baseline to deck at centreline of Station 0	462 mm	482 mm

Distance from hull datum point measured along base line to a point where extension of straight edge of foreside of stem (included keel band if any) meets base line		3705 mm	3735 mm
	300 mm below baseline	140 mm	150 mm
	180 mm below baseline	265 mm	285 mm
Horizontal distance from hull datum point to centre of centreboard bolt		2390 mm	2410 mm
Radius of chines aft of station 3		-----	15 mm
Length of keelband from hull datum point along keelband		3500 mm	-----
Radius of stem forward of 3500 mm		-----	11 mm
Width of keelband		9 mm	22 mm
Depth of keelband		3 mm	10 mm
Beam of hull , excluding rubbing strakes and fittings:			
*At sheerline			
At station 0	898 mm	918 mm	
At station 1	1228 mm	1248 mm	
At station 2	1408 mm	1428 mm	
At station 3	1150 mm	1170 mm	
*At chine			
At station 0	828 mm	848 mm	
At station 1	1136 mm	1156 mm	
At station 2	1244 mm	1264 mm	
At station 3	816 mm	836 mm	
Horizontal width of side decks		120 mm	240 mm

Height of side deck assembly above line joining sheerline on opposite sides of the hull	-----	40 mm
Depth of side deck assembly below line joining sheerline on opposite sides of the hull	-----	80 mm
Distance from a straight edge placed at right angles to the baseline on bottom panel at: At station 0 At station 1 At station 2 At station 3 on topside panel at any point (Diag H.1.8) N.B: This measurement (above) shall be taken between the sheerline and the chine and not from the underside of the rubbing strake.		15 mm 25 mm 30 mm 35 mm 8 mm
Height of continuation of centreline of deck above sheerline at centre of mast	20 mm	40 mm
Gunwale rubbing strakes; depth (vertically from sheerline) width (horizontally from sheerline)	9 mm 3 mm	35 mm 35 mm
Forward face of aft bulkhead from hull datum point	785 mm	815 mm
Aft face of forward cockpit bulkhead from hull datum point	1779 mm	1809 mm
Bulkhead at or forward of Station 3 (and aft of mast)	2800 mm	-----
Radius between bulkheads and hull side or bottom panels	-----	50 mm
Drain holes into cockpit from forward tanks	-----	2
Drain holes into cockpit from aft tanks	-----	2
Diameter of drain holes as above (internal)	10 mm	20 mm
Diameter of mast compartment drain tube (internal)	10 mm	20 mm
Diameter of inspection holes in tanks (internal)	85 mm	-----
Extension into buoyancy tank of covers to holes as above	-----	200 mm
Total cross sectional area of control line tubes passing through buoyancy tanks	-----	150 cm ²
Control line tubes from centreline of boat	-----	350 mm

Section E – Hull Appendages

E.1 GENERAL

E.1.1 RULES

- (a) **Hull appendages** shall comply with the **class rules** in force at the time of **certification**.
- (b) Alterations and replacements shall comply with current **class rules**.

E.1.2 CERTIFICATION

- (a) The **official measurer** shall **certify** the **hull appendages**.

E.1.3 MODIFICATIONS, MAINTENANCE AND REPAIR

- (a) **Hull appendages** shall not be altered in any way except as permitted by these **class rules**.

E.1.4 MANUFACTURERS

- (a) The **hull appendages** may be built by any amateur or professional builder.

E.2 CENTREBOARD

E.2.1 MATERIALS

- (a) The **centreboard** shall be built from one or a combination of:
 - (1) Wood (solid or laminated).
 - (2) GRP sandwich or wood sandwich.
- (b) **Centreboards** may be covered with gelcoat, resin, paint or varnish.
- (c) Protective strips of any materials are optional and may be integral to the **centreboard**.

E.2.2 CONSTRUCTION

- (a) The profile of the measured part of the **centreboard** (excluding any pivot slot) shall be within two lines; one 5 mm outside and the other 5 mm inside the profile shown on the measurement diagram, when the pivot point in the **centreboard** lies on the pivot point shown on the measurement diagram.
- (b) A slot may be made between the pivot point in the **centreboard** and the perimeter.
- (c) A device shall be fitted to prevent accidental dislodgement off the pivot.

E.2.3 FITTINGS

- (a) OPTIONAL
 - (1) Fittings to control the position of the **centreboard** are optional.

E.2.4 DIMENSIONS

	min	max
Thickness		20 mm
Thickness of centreboard above waterline as shown on diagram (inside 20 mm from edges)	10 mm	
Width of pivot slot	-----	12 mm
Free movement of centreboard on pivot bolt	-----	2 mm

Width of protective strip from profile edge as defined in the measurement diagram	-----	20 mm
---	-------	-------

E.3 RUDDER, RUDDER BLADE, RUDDER STOCK AND TILLER

E.3.1 MATERIALS

- (a) The **rudder** shall be built from one or a combination of the following materials.
- (1) Wood (solid or laminated).
 - (2) GRP sandwich or wood sandwich.
- (c) **Rudders** may be covered with gelcoat, resin, paint or varnish.
- (d) The **rudder** stock material, where used, is optional.
- (e) The tiller material is optional.
- (f) The tiller extension material is optional.
- (g) Protective strips of any material are optional and may be integral to the **rudder** or **rudder** blade.

E.3.2 CONSTRUCTION

- (a) The **rudder** shall consist of either a **rudder** blade or a **rudder** stock incorporating a **rudder** blade.
- (b) The arrangement of **rudder** blade, **rudder** stock, tiller and tiller extension is optional except that:
- (1) a tiller shall not be made integral to a **rudder** blade using exotic materials or CRP.
 - (2) a **rudder** stock made from exotic materials or CRP shall only be fastened to a **rudder** blade.
- (c) The profile of the measured part of the **rudder** shall be within two lines; one 5 mm outside and the other 5 mm inside the profiles (either Profile 1 or Profile 2) as shown on the measurement diagram.
- (d) Lifting **rudders** shall be able to be fixed in the down position with a pin or bolt separate from the pivot bolt.

E.3.3 FITTINGS

- (a) OPTIONAL
- (1) Any fittings are optional.
- (b) LIMITATIONS
- (1) Fittings made from exotic materials or CRP shall not be integral to the **rudder** blade.

E.3.4 DIMENSIONS

	min	max
Thickness below the waterline as shown on the measurement diagram.	-----	20 mm
Width of protective strip from profile edge as defined in the measurement diagram	-----	20 mm

Section F – Rig

F.1 GENERAL

F.1.1 RULES

- (a) The **spars** and their fittings shall comply with the **class rules** in force at the time of **certification** of the **spar**.
- (b) Alterations and replacements shall comply with current **class rules**.
- (c) The running **rigging** shall comply with these **class rules**.

F.1.2 CERTIFICATION

- (a) The **official measurer** shall **certify** the **mast** and **boom**.
- (b) No **certification** of running **rigging** is required.

F.1.3 MODIFICATIONS, MAINTENANCE AND REPAIR

- (a) **Spars** shall not be altered in any way except as permitted by these **class rules**.

F.1.4 DEFINITIONS

(a) MAST DATUM POINT

The **mast datum point** is at deck level on the aft centreline face of the **mast**.

- (b) A **spar** section is defined as the extrusion, moulding or tube that forms the basis of the **spar**.

F.1.5 MANUFACTURER

- (a) The **mast** and **boom** may be built by any amateur or professional builder, except that a licence is required for **mast** sections built using any materials other than wood or aluminium alloy, and subsequent alterations of more than one metre in length.
- (b) **Mast** licenses shall be issued by the OKDIA. The terms of the OKDIA Mast Building Licence may be subject to review from time to time by World Sailing and the OKDIA.

F.2 MAST

F.2.1 IDENTIFICATION

- (a) If the **mast** section is built using any materials other than wood or aluminium alloy the licenced builder shall permanently fix an official OKDIA mast label on the front of the **mast**, just above the gooseneck.

F.2.2 MATERIALS

- (a) The **mast** spar section shall be built from one or a combination of the following materials:
 - (1) Wood (solid or laminated).
 - (2) Aluminium alloy.
 - (3) GRP.
 - (4) CRP.
 - (5) ARP.
- (b) **Masts** may be anodised, painted or varnished.

- (c) The material for an external sail track is optional.
- (d) The material for the **mast** base and deck ring is optional.

F.2.3 CONSTRUCTION

- (a) The **mast spar** shall include a fixed sail groove or track which may or may not be integral with the **mast** section.
- (b) The aft side of the sail track or groove shall be constructed straight and the line of the track or groove, extended if necessary, shall be not more than 10 mm outside the aft edge of the **mast** bearing ring at the deck.
- (c) The cross section shape of a **mast** shall be a single geometrical figure and shall have no hollows on the outside with the exception of the sail track or groove.
- (d) **Mast** sections may be made as a two-piece or a three-piece section.
- (e) The only permitted additional items to the **mast** construction are:
 - (1) External sail track
 - (2) Internal connecting sleeves (when **spar** is a two or a three-piece section).

F.2.4 FITTINGS

- (a) MANDATORY
 - (1) With the exception of wood **spars**, a fixed fork fitting to connect the **boom**.
- (b) OPTIONAL
 - (1) Other fittings are optional.

F.2.5 DIMENSIONS

	min	max
Mast spar cross section; diameter at deck level incl. optional mast ring diameter at 20 mm above heel point	94 mm 70 mm	98 mm 76 mm
Mast spar transverse cross section at; from heel point to 1000 mm above mast datum point from 1000 mm above mast datum point to upper point minimum dimension is given by a uniform reduction of	62 mm Minus 1 mm for every 100 mm	----- -----

Mast spar fore-and-aft cross section at; *From heel point to upper point maximum dimensions is given by the actual transverse width <u>Plus 22 mm</u> at the same height. * Mast spar curvature at any point * Lower mast limit mark width * Upper mast limit mark width * Lower point to upper point	----- ----- 10 mm 10 mm and all above the upper point 5400 mm	----- 50 mm ----- ----- -----
Boom forks on mast: Internal width Diameter of boom pin hole Centre of pin hole from aft face of mast Centre of pin hole below lower point Distance from lower point to centre of gravity	32 mm 14 mm ----- 33 mm 1430 mm	40 mm 18 mm 39 mm 37 mm -----

F.2.6 WEIGHT

	min	max
Mast weight including mast base, deck ring, halyard, cleat, permanently attached blocks, any corrector weights , and excluding gooseneck pin	8 kg	-----

F.2.7 CORRECTOR WEIGHTS

Corrector weights of not more than 1.5 kg are permitted and shall be permanently attached to the external surface of the **mast**.

F.3 BOOM

F.3.1 MATERIALS

- (a) The **boom** spar section shall be built from one or a combination of the following materials:
- (1) Wood (solid or laminated).
 - (2) GRP.
 - (3) Aluminium alloy.
- (b) **Boom** sections may be anodised, painted or varnished
- (c) Any material may be used for an external sail track.

F.3.2 CONSTRUCTION

- (a) The **boom** spar shall include a fixed sail groove or track which may or may not be integral with the **boom** section.
- (b) The construction method of the **boom** is optional.

F.3.3 FITTINGS

- (a) OPTIONAL
 - (1) Any fittings are optional.

F.3.4 DIMENSIONS

	min	max
Boom spar cross section forward of the outer point :		
Vertical from 200 mm aft of the gooseneck hole transverse	50 mm -----	90 mm 37 mm
Outer limit mark width	10 mm	-----
Distance from outer point to centre of the gooseneck hole in boom	-----	2640 mm

F.4 RUNNING RIGGING

F.4.1 MATERIALS AND CONSTRUCTION

- (a) Materials and construction are optional.

F.4.2 FITTINGS

- (a) Fittings are optional.

Section G – Sails

G.1 GENERAL

G1.1 RULES

- (a) **Sails** shall comply with the **class rules** in force at the time of **certification**.
- (b) Alterations and replacements shall comply with the current **class rules**.

G.1.2 CERTIFICATION

- (a) **Sails** shall carry the official OKDIA sail label, purchased by the sailmaker from OKDIA. It shall be permanently attached near the tack by stitching across it.
- (b) The **official measurer** shall **certify** sails by stamping, or signing and dating, across the official OKDIA Sail label.
- (c) World Sailing or an MNA may appoint one or more persons at a sailmaker to measure and **certify** sails produced by that manufacturer in accordance with the World Sailing In-House Certification Guidelines.

G.1.3 SAILMAKER

- (a) No licence is required.

G.2 SAIL

G.2.1 IDENTIFICATION

- (a) The class insignia shall have a height of 200 mm +/- 20 mm and a width of 335 mm +/- 20 mm.

G.2.2 MATERIALS

- (a) The **ply** fibres shall consist of polyester.
- (b) **Stiffening** shall consist of:
- (1) Corner-boards: plastic or aluminium.
 - (2) Battens: Material optional.
- (c) **Sail reinforcement** shall consist of:
- (1) **Primary reinforcement**: Any permitted material.
 - (2) **Secondary reinforcement**: as per ERS definition.

LIMITATIONS

- (d) **Sail** makers are only permitted to build **sails** from laminated sail cloth upon request and approval by the OKDIA Technical Committee and on a sail by sail basis. For laminate **sails** only, rules G.2.3 (a), (b) & (c) and all dimensions from G.2.4 except **leech length, half & three quarter widths** and **top width** shall not apply, if the approval document from the OKDIA is presented when measuring. The use of those **sails** is allowed in any OK regatta with the exception of International events.

G.2.3 CONSTRUCTION

- (a) The construction shall be: **soft sail, single ply sail**.
- (b) The **body of the sail** shall consist of the same **woven ply** throughout.
- (c) A foot shelf of not more than 300 mm width is permitted to be of a different material. For the purpose of this rule a foot shelf is defined as a panel or panels of material, attached to the **body of the sail** and which is continuous between the clew eye and the tack eye and which shall taper to a point at the tack eye and clew eye.
- (d) The **sail** shall have 4 batten **pockets** in the **leech**.
- (e) The **leech** above the upper **batten pocket** shall not extend beyond a straight line, drawn from the **aft head point** to the upper edge of the upper **batten pocket**.
- (f) The following are permitted: Stitching, glues, webbing, woven and PTFE tapes, bolt ropes, corner eyes, headboard with fixings, Cunningham: one eye or not more than two pulleys, **batten pocket patches, batten pocket** elastic, batten retaining devices, boom slides, leech line, windows, tell tales, sail shape indicator stripes, headboard slides not extending more than 175 mm from the **head point** and items as permitted or prescribed by other applicable rules. All permitted items shall be used for their intended purpose.

G.2.4 DIMENSIONS

	min	max
Leech length	-----	5425 mm
Half width	-----	1675 mm
Three-quarter width	-----	1040 mm
Top width	-----	160 mm

Primary reinforcement	-----	350 mm
Secondary reinforcement:		
from sail corner measurement points	-----	1050 mm
for flutter patches	-----	120 mm
for batten pocket patches	-----	175 mm
Tabling width on luff and foot	-----	60 mm
Tabling width elsewhere	-----	35 mm
Total window area	-----	0.3 m ²
Window to sail edge	150 mm	-----
Extension of headboard from head point	-----	175 mm
Batten pocket length:		
uppermost and lowermost pockets	(inside)	605 mm
intermediate pockets	(inside)	755 mm
Batten pocket width	(inside)	60 mm
Head point to intersection of leech and centreline of uppermost batten pocket	1000 mm	1200 mm
Clew point to intersection of leech and centreline of lowermost batten pocket	1000 mm	1200 mm
Head point to nearest point of luff bolt rope	-----	50 mm
Tack point to nearest point of luff bolt rope	-----	300 mm
Tack point to nearest point of foot bolt rope	-----	450 mm
Clew point to nearest point of foot bolt rope	-----	100 mm

PART III – APPENDICES

The rules in Part III are **closed class rules**. Measurement shall be carried out in accordance with the ERS except where varied in this Part.

Section H

H.1 MEASUREMENT DIAGRAMS

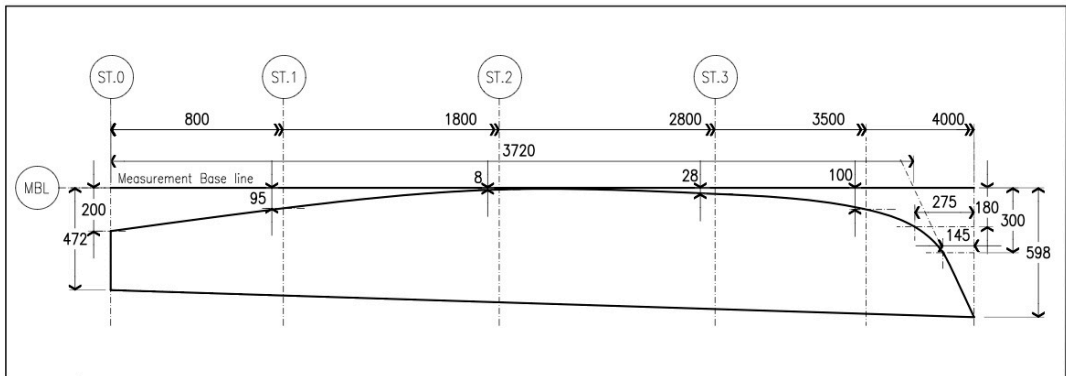

H.1.1 HULL DIMENSIONS AT KEEL

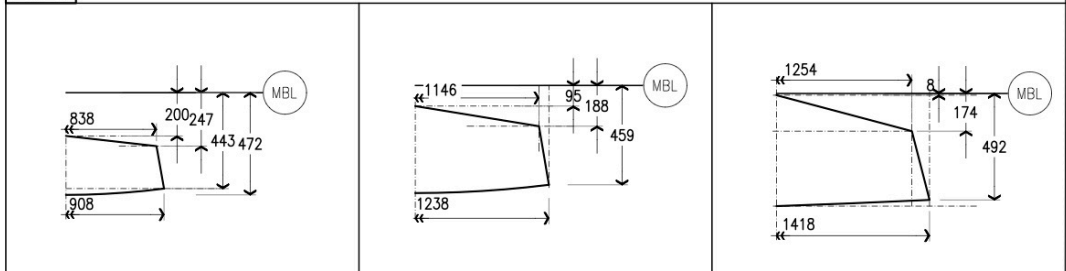

H.1.2 HULL DIMENSIONS AT STATION 0 H.1.3 HULL DIMENSIONS AT STATION 1 H.1.4 HULL DIMENSIONS AT STATION 2



H.1.5 HULL DIMENSIONS AT STATION 3 H.1.6 ROUNDED CHINE MEASUREMENT POINT

HULL MAXIMUM BOTTOM PANEL CURVATURE SCHEDULE	
STATION	MAXIMUM CURVATURE DIMENSION "X" IN FIG H1.7
0	15MM
1	25MM
2	30MM
3	35MM



(ST.0) : MEASUREMENT STATION NUMBER
 (MBL) : MEASUREMENT BASE LINE

H.1.7 HULL MAXIMUM BOTTOM PANEL CURVATURE

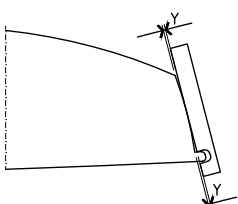
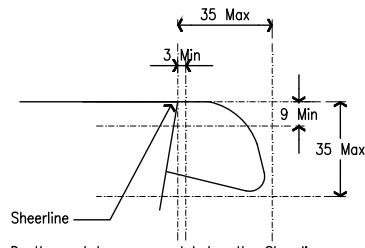
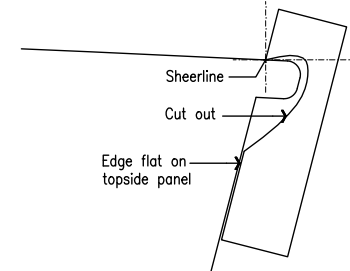
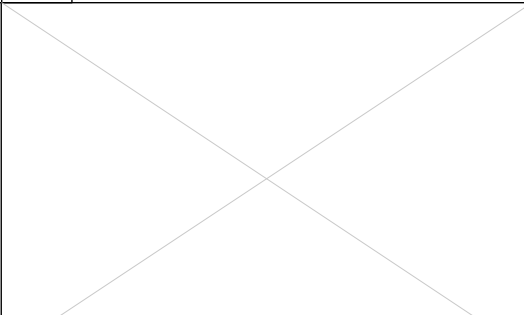
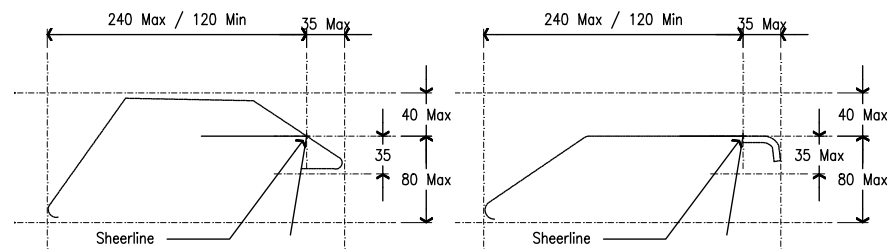
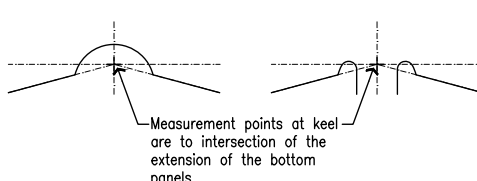
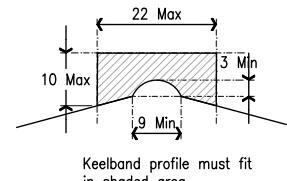

INTERNATIONAL OK DINGHY MEASUREMENT DIAGRAM
 APPENDIX H

SCALE 1:25
 DATE JUNE 2017

<p>MAXIMUM CURVATURE DIMENSION "Y" SHALL NOT BE GREATER THAN 8MM</p> 	 <p>Depth must be measured below the Sheerline</p>
<p>H.1.1.8 TOPSIDE CURVATURE SCALE - 1:20 @ A4</p>	<p>H.1.1.9 GUNWALE PROFILE SCALE - 1:2 @ A4</p>
	
<p>H.1.1.10 SHEERLINE GAUGE SCALE - 1:5 @ A4</p>	
<p>H.1.1.11 SIDE DECK AND GUNWALE SCALE - 1:5 @ A4</p>	
 <p>Keelband profile must fit in shaded area.</p>	<p>H.1.1.12 KEEL MEASUREMENT POINTS SCALE - 1:2 @ A4</p>
<p>H.1.1.13 KEELBAND PROFILE SCALE - 1:1 @ A4</p>	
<p>INTERNATIONAL OK DINGHY MEASUREMENT DIAGRAM</p> <p>APPENDIX H</p>	<p>SCALE @ A4 DRAWING</p> <p>REV -</p> <p>AS SHOWN DATE JUNE 2017</p>

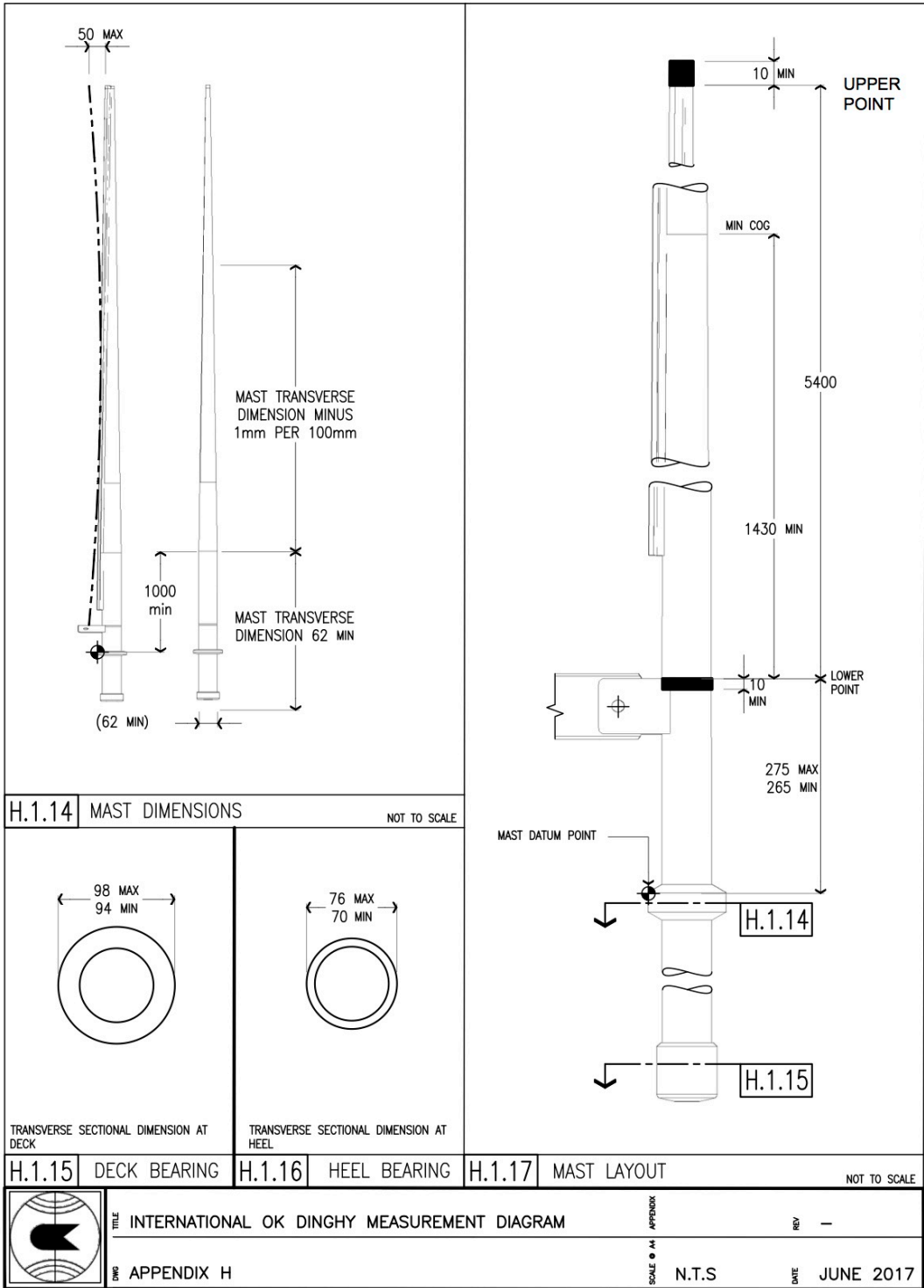

H.1.14 MAST DIMENSIONS NOT TO SCALE

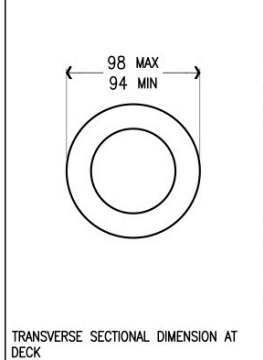

TRANSVERSE SECTIONAL DIMENSION AT DECK

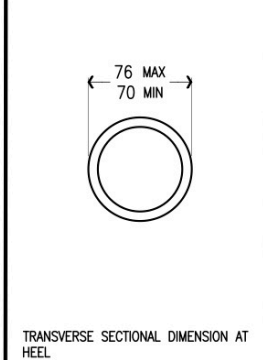

TRANSVERSE SECTIONAL DIMENSION AT HEEL

H.1.15 DECK BEARING

H.1.16 HEEL BEARING

H.1.17 MAST LAYOUT NOT TO SCALE



TITLE	INTERNATIONAL OK DINGHY MEASUREMENT DIAGRAM	APPENDIX	REV	-
APPENDIX	APPENDIX H	SCALE	N.T.S	DATE
				JUNE 2017

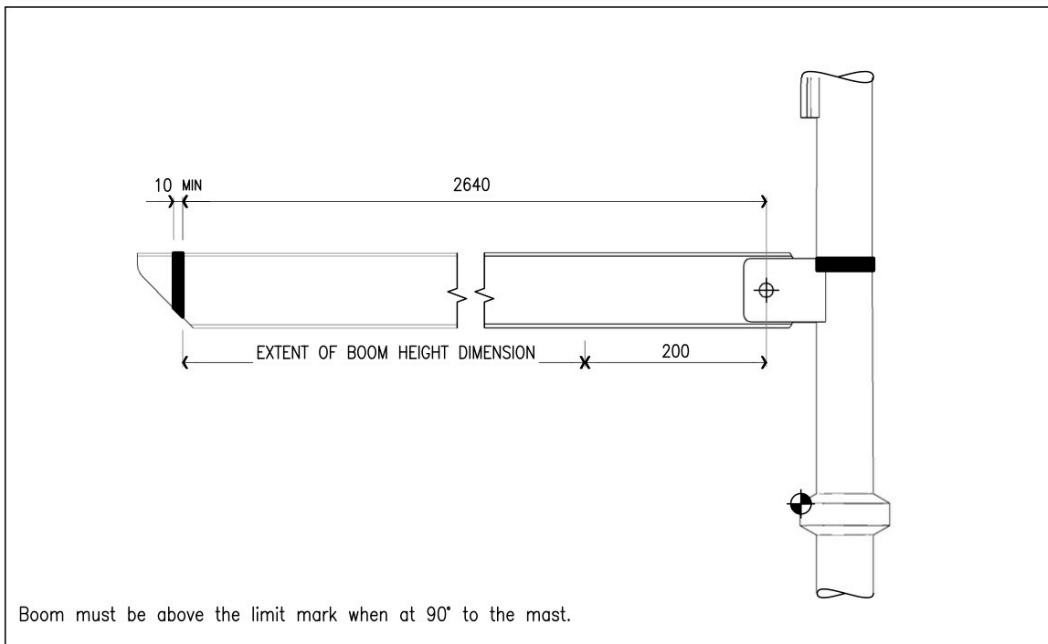

H.1.18 BOOM LAYOUT NOT TO SCALE

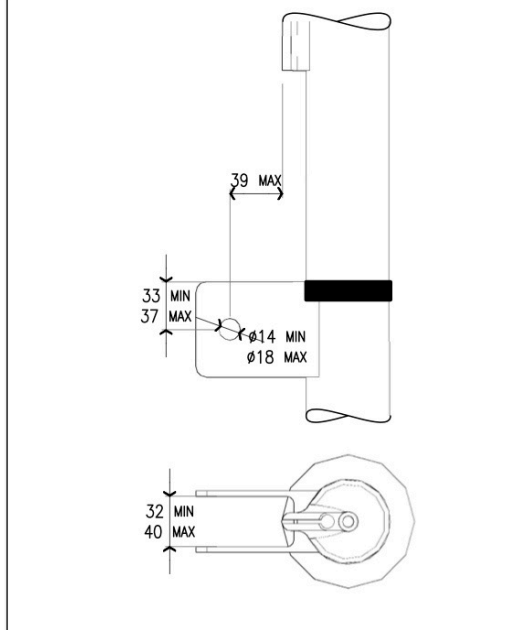
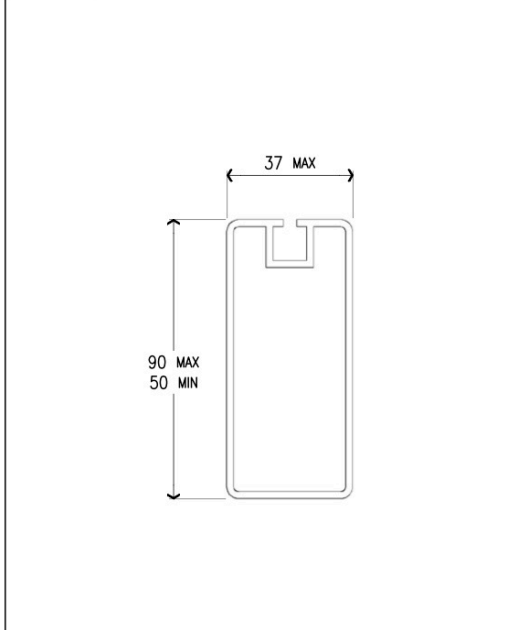

H.1.19 BOOM SECTION NOT TO SCALE H.1.20 GOOSENECK DIMENSIONS NOT TO SCALE

	TITLE	INTERNATIONAL OK DINGHY MEASUREMENT DIAGRAM	APPENDIX	REV	—
	ENVS	APPENDIX H	SCALE	N.T.S	DATE

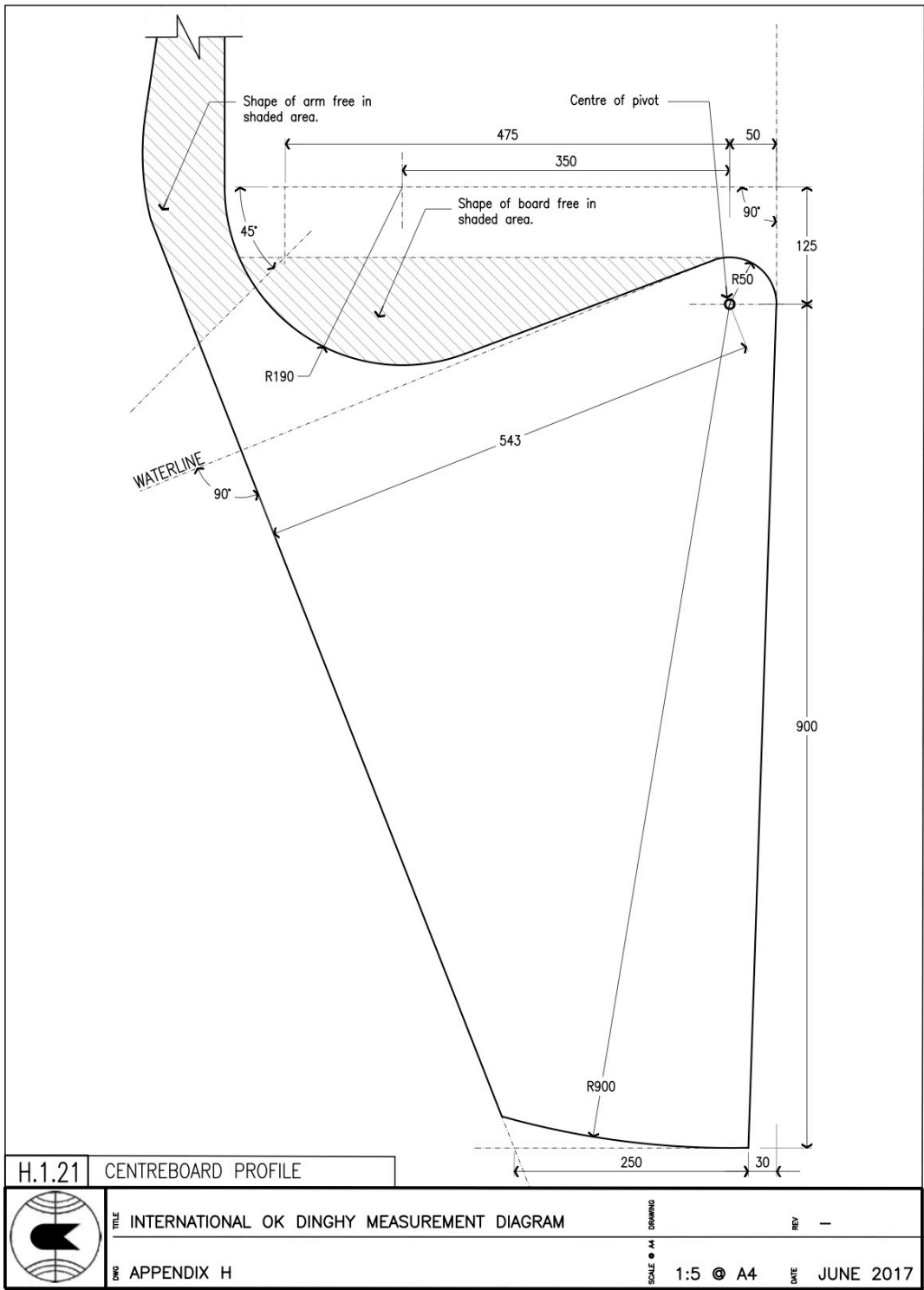

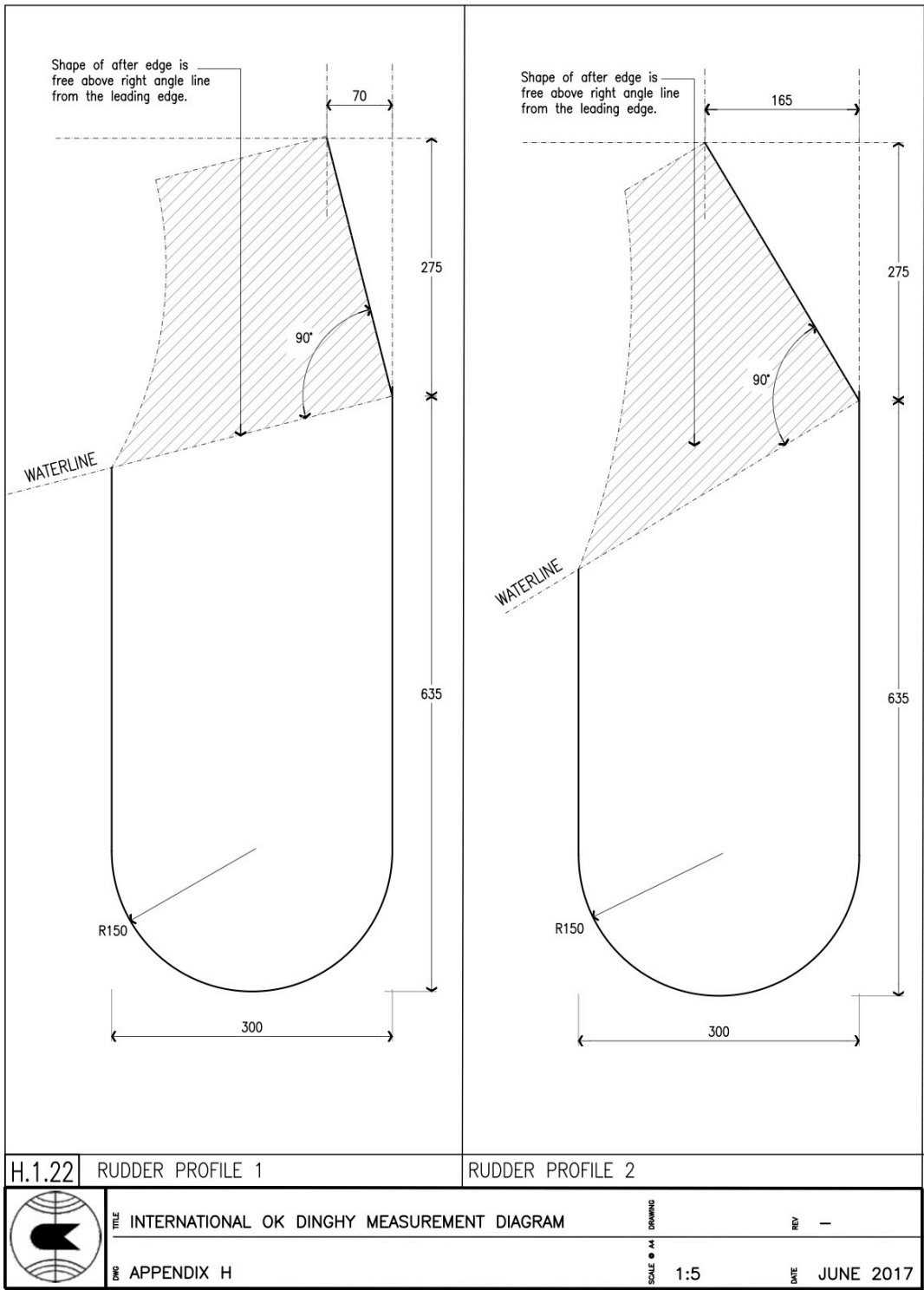

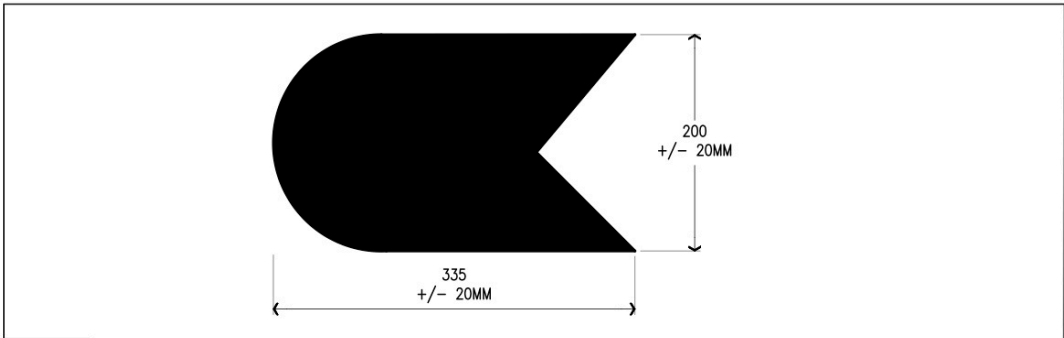

H.1.23 SAIL INSIGNIA



	TITLE	INTERNATIONAL OK DINGHY MEASUREMENT DIAGRAM	SCALE	1:2	REV	—
	DWG	APPENDIX H	DATE	JUNE 2017		

H.2 OFFICIAL PLANS

1	General arrangement and construction details	1986
2	Full size details	1986

H.3 DEFINITIONS

Where shown in the **class rules** – the following abbreviations or descriptions mean:

Fastened – joined using rivets, screws or bolts.

Attached – joined using sealant or glue. May also be fastened.

Integral – joined using ARP, GRP or CRP. May also be attached and/or fastened.

GRP (Glass Reinforced Plastic) – A composite material made from glass fibres bonded with polyester, epoxy or vinylester resin.

CRP (Carbon Reinforced Plastic) – A composite material made from carbon fibre bonded with polyester, epoxy or vinylester resin.

ARP (Aramid Reinforced Plastic) - A composite material made from aramid fibre bonded with polyester, epoxy or vinylester resin.

GRP Sandwich – A composite sandwich material made from glass fibres bonded with polyester, epoxy or vinylester resin and having a core material of foam, wood and/or cormat.

Wood Sandwich – A composite sandwich material made from wood and having a foam core, bonded with polyester, epoxy and/or vinylester resin.

Exotic materials – non metallic materials which may include thermoplastics, thermosets, ceramics and composite products reinforced with materials not defined above.

Effective: 11th May 2020

© World Sailing 2020